

Top Rail / Midrail & Bottom Rail

Bikeway barrier with offset top rail, midrail and bottom rail for level and rake



Key features

- > Modular flexibility
- > No-weld assembly
- > Flat pack delivery
- > Reduced corrosion
- > Colour options
- > Available ex-stock
- > BIM & CAD Support

Applications suited to

- > Cycle paths and bikeways
- > Shared pedestrian paths
- > Protection over culverts
- > Footbridges
- > Refer to applicable NZ Standards and Building Codes.

Specification Summary

Supply and install the proprietary BS30 barrier system to substrate according to Moddex specifications, or by a Moddex accredited installer.

Technical Data

Material

Stanchions, rails & balustrades	Steel/grade C250 & 350
Clamp fittings	Malleable Cast iron
Clamp locking screws	Stainless steel (304)

Protective coating

Stanchions, rails and balustrades	G390 Hot-dip Galvanized (min 390g/m ²)
Clamp fittings	Hot-dip Galvanized with patented protective coating on threads
Optional	Powder coating and paint specs*

*The standard process for Powder Coated and Painted handrail products is as follows: black steel is used for fabrication. The steel is sand blasted and a zinc primer coating is applied. The powder coat / paint coat is then applied over the zinc primer creating a dual shield coating with a decorative finish.

Dimensions

Variable depending on building/application/ code

Stanchions

Diameter	48.3mm OD 41.9mm ID
Nominal Thickness	3.2mm - 4.0mm (loading dependent)

Rails

Diameter	48.3mm OD 41.9mm ID
Nominal Thickness	3.2mm

Clamp fittings

Thickness	5.0mm (approx)
Locking screws	M12 x 1.75 x 11mm - DEXX [®] Drive

Weight

Variable depending on building/application/ code

Stanchion with clamps	7.2 to 8.0kg
Rail @ 6.0m	21.6kg
Balustrade Panel @ 2.0m	29kg

Fixings

Stanchion attachment to

Concrete	M12 galvanized mechanical concrete anchor
Structural steel	M16 galvanized high tensile bolt set

*Other Fixing options are available on request

Compliance

Moddex balustrades and handrails are designed and manufactured in accordance with New Zealand Building Code and the NZTA Bridge Manual and relevant statutory WHS Codes of Practice/Guidelines. Galvanized to AS 4792 and AS/NZS 4680:2006 (where applicable).

Testing

Stringent vibration endurance tests have been performed and independent testing has been carried out to confirm the suitability of the Moddex system in maritime conditions. Tested and certified to AS/NZS 1170 C3 loadings.

Warranty

5 years from date of purchase subject to correct installation, use and maintenance in accordance with manufacturer's specifications and recommendations, unless otherwise negotiated at the time of purchase.
— Refer maintenance manual

Inspection & Maintenance

Visual inspection for any damage or loose fixings must be done periodically and prior to use. No certified maintenance required. Basic wear and tear preventative maintenance is recommended, as per manufacturer's specifications and recommendations.
— Refer maintenance manual

Basis of Design

When designed as per the Moddex PS1

1. Design Life: 50 years minimum
2. Building Occupancy: B, E
3. Loadings: AS/NZS 1170.1:2002 - Table 3.3 AS 1657:2013 - CL6.1
4. Live Loadings: Line: 0.35 kN/m
Concentrated: 0.6 kN
Infill: N/A

BPIR

BPIR, set new minimum requirements for the level of information required about building products supplied to the New Zealand market. Moddex is committed to meeting these requirements - download the latest information here:

<https://moddex.com/resources/downloads/#bpir-sheets>

Technical Information

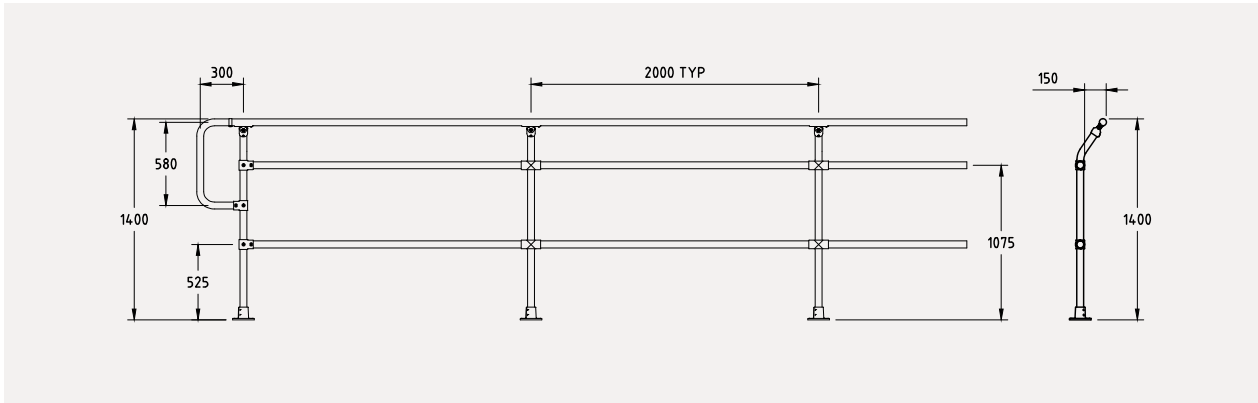

Mount Dimensions

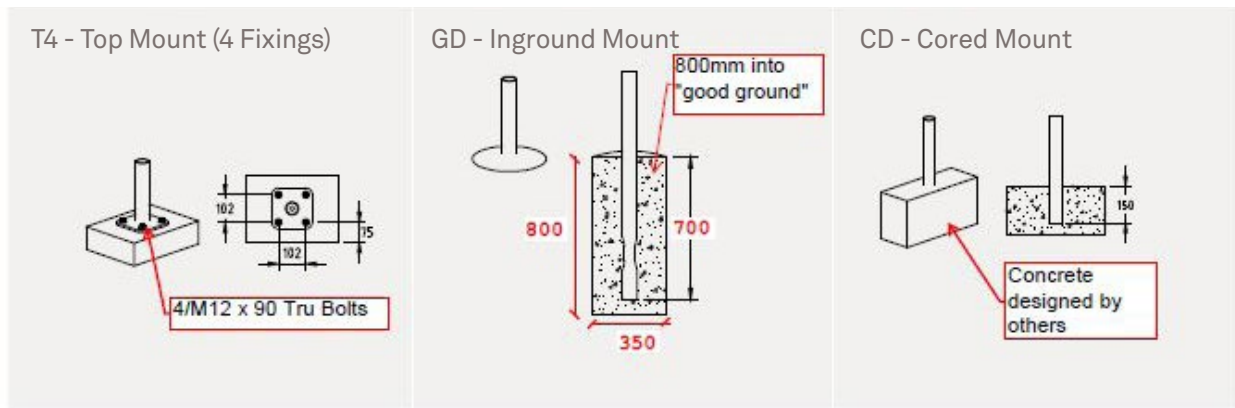

Standard References

New Zealand Building Code

- When a ramp, stair or landing is situated so that a person could fall 1m or more, then a barrier shall be provided that meets the requirements of NZBC Clause F4 Safety from falling.

[DOWNLOAD OUR GUIDE TO HANDRAIL & BALUSTRADE COMPLIANCE HERE](#)

NZTA Bridge Manual

B2.4 Pedestrian Barrier:

Bikeway barriers should not be used for the restraint of vehicles and should only be used in the following locations:

- On a structure provided for the sole use of pedestrians, i.e. not motorised traffic
- On the outside of a footpath on a structure that is separated from the motorised traffic by a semi-rigid barrier or a rigid barrier.

B2.5 Cyclist Barriers:

The principles described in B2.4 also apply to the protection of cyclists, with barriers similarly only being used on dedicated structures or outside of paths on structures that are separated from motorised traffic by a semi-rigid barrier or a rigid barrier.

The minimum height to the top edge of the top rail for a cyclist barrier shall be:

- 1200mm where the risk of angled collision resulting in a cyclist vaulting over the barrier is considered low
- 1400mm where the risk of angled collision or launch is high.
- This would typically be at tight bends or junctions (radius less than 25m) or where cyclists travel at high velocities (greater than 40km/h).